

650  
*mini*



**JANUS**  
INTERNATIONAL



*superior product + recognized value*



*The Janus Model 650 Mini Storage Door is designed and manufactured with durability, quick installation and ease of maintenance in mind. Features standard to this door eliminate the need for extra options or upgrades. The best door...the best value...*

*That's the Janus Advantage*

## FEATURES

### DOOR SPRINGS

During production, each spring is coated with a generous amount of grease that penetrates the innermost pores of the spring with additives, displacing moisture and preventing the formation of rust and corrosion. In addition, this process relieves the friction created between spring coils, thereby providing a smoother door operation. Finally, the spring and axle assembly is enclosed in a tube to protect them from the elements encountered throughout the life of the door.

### OPTIONAL PACKAGE PROTECTION & SHIPPING

Doors stacked on top of each other in transit are going to shift... unless they can be packaged in a way to minimize the sliding that occurs during that time. Janus has found the way. As an option, we can suspend each door individually in crates. Whether they travel down the block or across the country, compaction damages, door abrasions and chatter marks are virtually eliminated.

### RATCHET TENSIONING DEVICE

The Janus ratchet tensioning device, supplied as standard equipment on our door, offers a simpler method of tensioning while more accurately fine tuning all the springs on the door at the same time. There is no extra hardware required. Eight different positions on the tension wheel allow one to perfectly balance the door every time. There are no pins required to hold the tension on the spring... you simply just click it.

### RADIAL BALL BEARINGS

Janus supplies radial ball bearings at no additional cost to you. Our permanently-lubricated bearings require no maintenance and are guaranteed to last the entire life span of the door.

### DEAD AXLE & TORQUE TUBE ASSEMBLY

This design, noted for its durability and smoother operation with commercial applications, has now been incorporated into the Janus self storage door. The tube housing protects the springs and strengthens the axle. Eliminating axle push and shift that can occur with a live axle, the dead axle design allows for a straighter travel path of the door curtain in the guides. The greatest feature of this design is that it affords the fine tuning of any spring adjustment to equally affect all springs on the door at the same time.

### DOOR STOPS

Our removable door stops are simple to install and prevent the curtain from over traveling the guide when raising the door.

### MAGNETIC ZINC COATED STEEL OR OPTIONAL STAINLESS STEEL LATCH

Our patented mini latch features a cover plate made from a heavy gauge yellow zinc coated steel or optional stainless steel. In addition, the latch cover protects the slide from tampering by completely covering the slide, with the exception of a tab used to operate the latch. To further secure the door, the latch's two inch throw, with its magnetic properties, can be incorporated with the new guide-mounted security devices. This versatile design affords you the ability to utilize padlocks, cylinder locks or both.

### DOOR HANDLE

The Model 650 features an external handle manufactured of Acrylonitrile-Styrene-Acrylate (ASA), which is an Engineered Terpolymer. ASA materials better withstand outdoor applications, adding higher rigidity as well as greater resistance to rust, moisture, high temperatures and chemicals.

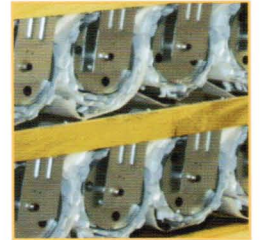
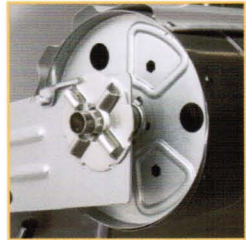

superior product + recognized value

Three manufacturing facilities located throughout the United States and a team of experienced door experts are available to assist you with any of your door needs.

Three year warranty on workmanship and material.

# 650 mini

All **DRUMS** are fitted with a grease filled, shielded radial ball bearing to contribute to a smoother operation and reduce wear and friction.

Factory installed galvanized reinforced 16 gauge **BRACKETS** (12 gauge for doors over 9' wide or 8' tall) are designed to easily snap onto the guides, reducing installation time.

Galvanized, guide-mounted **HEAD STOPS** are simple to install and prevent curtain over travel when raising the door. Installed through guide after curtain is lowered, they provide definite contact with the bottom bar angle and stop clips.

The **RATCHET SPRING TENSIONER ASSEMBLY** is factory installed on the end of the door axle and allows precise fine tuning of the initial spring tension. Increments of 1/8 turn are possible. Tensioner adjusts both springs equally at the same time from only one end of the door.

Roll formed clear acrylic coated galvanized steel **BOTTOM BAR** reinforced with a 1-1/2" x 1-1/2" 14 gauge full width galvanized angle that extends fully into the guides. The PVC bulb astragal provides positive contact with floor. Lift handle(s) and stop clips installed on exterior side of bottom bar and a non-rotting pull rope is attached to the inside angle.

Oil-tempered helical torsion **SPRINGS** are factory lubricated to minimize friction and corrosion while increasing the spring cycle life. Spring wire conforms to ASTM A 229.

Full width galvanized steel **BARREL** totally encloses the drums, springs and axle. Barrel-type construction reduces door sag, eliminates drum dents and improves operation due to an even support of the curtain for the entire width.

Galvanized and pre-painted with long lasting Super Durable polyester paint, the 26 gauge **CORRUGATED CURTAIN** is roll formed from ASTM A 653 grade 80 full hard steel. This premium steel yields greater door strength and minimized curtain damage. Full height felt tape on back of curtain prevents nesting and reduces paint rubbing. 20 colors are standard, with others available on special order. Available in sizes up to 10'0" x 10' 0".

Roll formed, 18 gauge galvanized **GUIDES** are fitted with dual polyethylene wear strips to reduce friction and muffle door noises. All guide attachment to jamb is performed through the guides without the addition of clips welded to the back of the guide. This gives a neater appearance, increased strength and aids in tight installations.

Yellow zinc coated steel or optional stainless steel cover, slide and four attachment bolts are factory installed. The slide exhibits magnetic properties that can be used to activate a guide mounted security sensor. **LATCH** accepts all industry padlocks, including 7/16" diameter shanks. Provision for cylinder lock included.

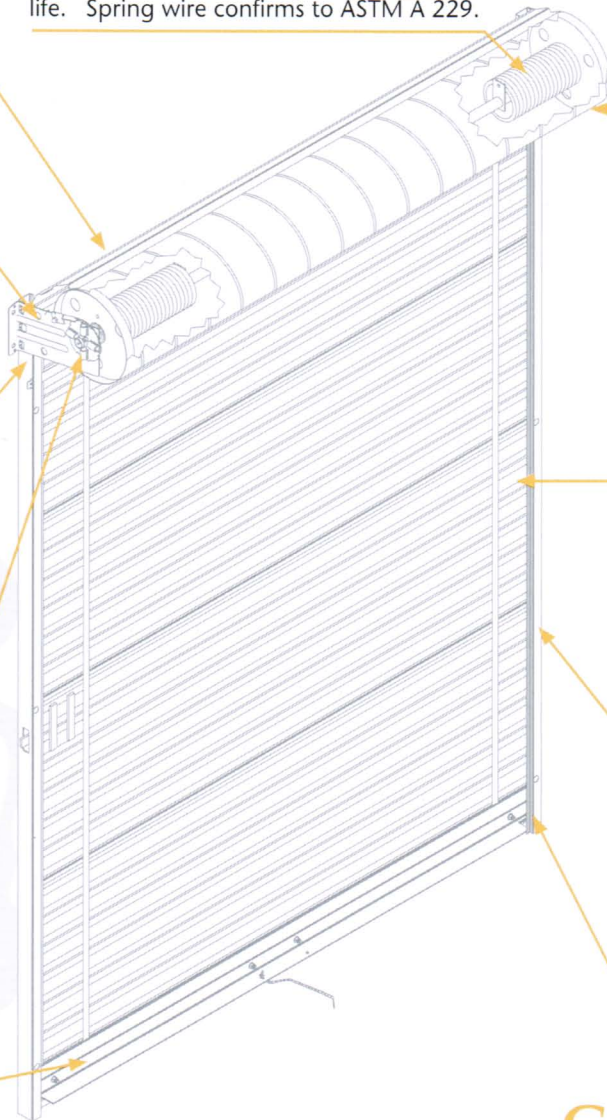

## GUIDE DETAILS

### UNIVERSAL MOUNT GUIDES

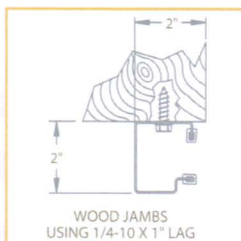

WOOD JAMBS  
USING 1/4-10 X 1" LAG

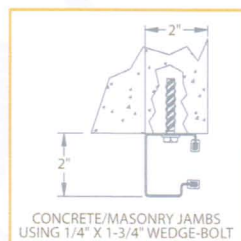

CONCRETE/MASONRY JAMBS  
USING 1/4" X 1-3/4" WEDGE-BOLT

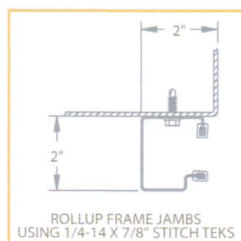

ROLLUP FRAME JAMBS  
USING 1/4-14 X 7/8" STITCH TEKS

### LIP DETAIL



RAIN LIP DETAIL

# 650 mini

superior product + recognized value

## JANUS INTERNATIONAL CORPORATION

Janus International Corporation specializes in the production of storage facility components, ranging from roll-up doors to self-sustaining hallway systems. The expertise and assistance provided to the customer, from designing the unit mix to the final job site punch out, is what sets our operation above the competition. Our meticulous attention to detail with the prints, manufacturing process, shipping, and installation offers every one of our customers the assurance that they are getting the best product available on the market. These qualities and services keep Janus' customers coming back for all their self storage door requirements.

### Head Room Requirements

Opening Height	Vertical Headroom	Horizontal Headroom
Thru 7' 4"	15-1/2"	17"
Over 7' 4" thru 8' 8"	16"	17-1/2"
Over 8' 8" thru 10' 0"	17"	18-1/4"

### Side Room Requirements

To Outside of Bracket Leg (both ends)	To End of Axle (both ends)
3-3/16"	3"

## JANUS INTERNATIONAL

### { headquarters }

p.o. box 567  
temple, georgia 30179

### { manufacturing facilities }

134 janus international blvd.  
temple, georgia 30179

+  
1256 brittmore road  
houston, texas 77043

+  
13374 west peoria avenue  
surprise, arizona 85379

+  
2535 west la palma avenue  
anaheim, california 92801

+  
davy drive; north west industrial estate  
peterlee; co durham SR8 2JF united kingdom

### { distribution center }

15330 valley view ave, suite 5  
la mirada, california 90638

PH **1 866 562 2580**  
FX **1 770 562 0328**

www.janusintl.com

revised 9/14/09

proud member of:



### INSTALLATION

Time is money. Janus saves you time by shipping your self storage door with the latch, brackets and tensioner already in place. With the Janus door, you simply snap the brackets into the guides and the door is ready to stand. Comprehensive installation instructions are shipped with every job. Furthermore, an installation video is available on our website to show you just how easy it is to install.

### WARRANTY

The Series 650 door and its components are warranted to be free of defects in workmanship and material for THREE YEARS. Our paint warranty offers a 40 year film integrity and a 25 year no-fade policy. Other provisions apply. Please refer to our official warranties for specific details.