

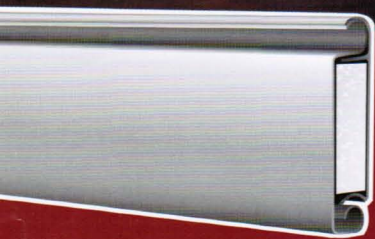

SERIES 6000

Service & Insulated Doors



Cross-section of an insulated slat.



CLASSIC ENGINEERING

C.H.I. Rolling Service Doors are computer-engineered with time-proven principles and designs. The result is a well-tuned, high-performance coiling door.

MAXIMUM VALUE

At C.H.I. we understand that the architect, building owner, installer and service technician each seeks value with absolute reliability. The Series 6000 simplifies the process of selection by integrating the highest design principles into standard features. Simply stated, Series 6000 Service Doors are manufactured to meet your highest expectations of quality, fit and function with no excuses.

DETAILS COUNT

Series 6000 Service Doors are available with curved or flat slat service curtains as well as fully weather-sealed and insulated curtains. A standard white back and hood provide a bright, light-reflecting interior surface. Guides feature a medium black primer coat that matches well with standard paint colors, as well as many powder-coat choices. Curtains are offered in solid gray, gray and white or tan and white paint finishes.

INDUSTRIAL HERITAGE

Structural steel angles are used to fabricate guides for maximum strength and durability. Curtain gauge selection may be made from 22, 20 and 18-gauge galvanized, high-tensile steel. Precision, self-aligning ball bearings support both tension and drive components. The entire spring assembly is designed for simple field removal and inspection. Hoods are formed in a half-hexagonal shape for structural rigidity and aesthetic appeal. Chain hoist operation is a standard feature, and motor operation is available with a full array of safety and activation options.

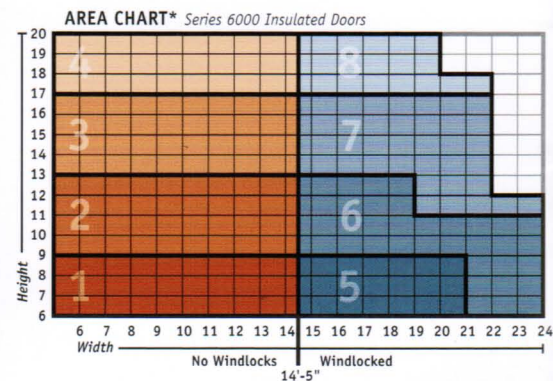

zone	H	B	T	D	X	Y	Z
1	15"	16"	6"	8-1/2"	3-7/8"	4-3/8"	6-1/2"
2	17"	18"	6"	8-1/2"	5"	4-3/8"	6-1/2"
3	19"	20"	6"	8-1/2"	5"	4-3/8"	6-1/2"
4	21"	22"	6"	8-1/2"	5"	4-3/8"	6-1/2"
5	17"	18"	6-1/2"	9-1/2"	6"	4-3/4"	7-1/2"
6	19"	20"	6-1/2"	9-1/2"	6"	4-3/4"	7-1/2"
7	21"	22"	6-1/2"	9-1/2"	6"	4-3/4"	7-1/2"
8	23"	24"	6-1/2"	9-1/2"	6"	4-3/4"	7-1/2"

Consult factory if headroom is critical or for sizes not listed.

Note: For downloadable specifications, please visit our website at www.chiohd.com

SPECIFICATIONS

PART 1 - GENERAL

1.01 WORK INCLUDED: Rolling service doors to be C.H.I. Service Series 6000, flat or curved slat.

1.02 RELATED SECTIONS:

- a. Section 04200 Concrete Block
- b. Section 05500 Metal Fabrications
- c. Section 06100 Wall Construction
- d. Section 08300 Access Doors
- e. Section 09900 Painting
- f. Section 16000 Electrical

1.03 SUBMITTALS:

- a. Furnish all submittals according to guidelines of Section 01300 Submittal Procedures.
- b. Shop Drawings: Furnish shop drawings for architectural approval including elevations and details showing dimensions, finishes, profiles and sections for each door.
- c. Product Literature: Submit manufacturer's brochures and literature describing product to be used.
- d. Provide manufacturer's installation instructions.

1.04 DELIVERY, STORAGE AND HANDLING:

- a. Refer to Section 01660 Material Storage and Handling Requirements.
- b. Deliver and store all materials in manufacturer provided packaging and protect from damage in a safe and dry location.

1.05 WINDLOAD:

- a. Provide doors designed to withstand 20 pounds per square foot of windload.
- b. Limit slat deflection to an amount that prevents curtain from buckling or being blown out of guides.

1.06 WARRANTY: Provide manufacturer's standard five-year warranty from date of plant shipment against defects in materials and workmanship.

PART 2 - PRODUCTS

2.01 GENERAL: Items and components described in the following paragraphs reflect current products manufactured by C.H.I. Overhead Doors, Inc, P.O. Box 260, Arthur, Illinois, 61911, and may be changed without notice by the manufacturer without penalty or liability.

2.02 CURTAIN: Interlocking curtain slats roll-formed from 22, 20 or 18-gauge steel. Insulated curtain slats contain EPS insulation and 24-gauge steel backers. Lateral slat movement and curtain wear controlled by galvanized, malleable cast iron endlocks fastened to every other slat. Windlocks added as dictated by door size and windload. Flat Slats (FS): cover 2-1/2 inches high by 3/4 inch deep. Curved Slats (CS): cover 2-5/8 inches high by 7/8 inch deep. Insulated Slats (IS): cover 2-1/2 inches high by 13/16 inch deep.

2.03 BOTTOM BAR: Fabricated from two steel angles bolted back-to-back, with adjustable tubular bottom astragal.

2.04 GUIDES: Fabricated from three minimum 3/16 inch structural steel angles, bolted together to form guide channel.

2.05 HEADPLATES: Headplates for mounting the curtain, hood, and barrel assemblies fabricated from minimum 1/4 inch steel plate. Drive side of barrel to be provided with precision, greaseable, sealed ball bearings in cast iron housing.

2.06 BARREL: Barrel fabricated from minimum 4-1/2 inch O.D. steel pipe. Deflection under full load not to exceed 0.03 inches per foot of span. Barrel provided with threaded rings or lugs welded to the barrel assembly for curtain attachment.

2.07 SPRINGS: Spring, (tension) assembly supported within barrel by precision ball bearings. Curtain weight counterbalanced by oil-tempered, helically wound torsion springs, grease packed and mounted to steel torsion shaft with cast spring plugs. Spring assembly designed for 20,000 cycle life standard. (Higher cycles optional.)

2.08 HOOD: Hood fabricated from minimum 24-gauge steel sheet, shaped to fit within headplates. Intermediate hood support(s) furnished as required.

2.09 LOCKING: Manual push-up doors furnished with interior plated steel slide bolt locks with padlock provisions. Chain hoist operated doors furnished with chain keeper suitable for padlocking.

2.10 OPERATION: Manual push up, chain hoist, (standard), or motor operation.

2.11 FINISHES: Curtain slats and hood hot-dipped galvanized, per ASTM A-653, G-90, with baked epoxy primer and polyester finish coat in solid gray, gray and white or tan and white. Guides and headplates shop painted black. Bottom bars to be shop painted or galvanized. Hot-dipped galvanized guides and bottom bars optional. Powder-coating is optional.

PART 3 - EXECUTION

3.01 EXAMINATION:

- a. Examine site and notify architect of non-specified conditions or construction.
- b. Advise procedures and corrections necessary to accommodate installation.

3.02 INSTALLATION: C.H.I. rolling steel doors shall be installed and adjusted according to C.H.I. assembly instructions by trained door systems technicians.

3.03 CLEANING AND PRESENTATION:

- a. Clean all finished surfaces after installation for a factory original appearance.
- b. Replace any damaged components before final inspection.
- c. Remove all packaging and debris from installation area at the completion of installation.
- d. Present operation and maintenance instructions to owner after demonstrating proper care and operation of door.

HEADER CLEARANCES & DIMENSIONS (INCHES)

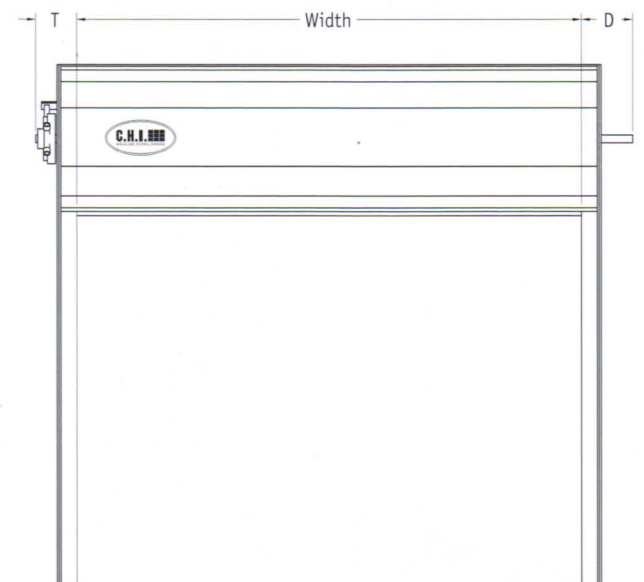
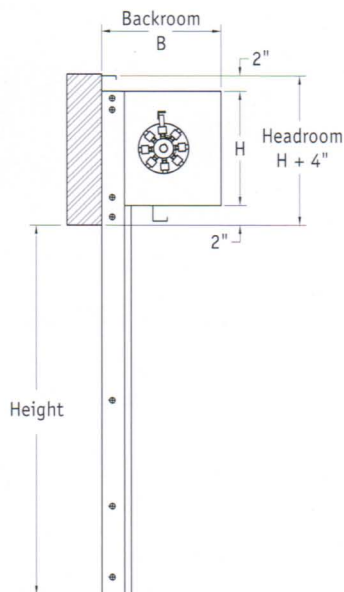

DETAILS

CLEARANCES & DIMENSIONS

- 1. Steel
- 2. Wood or Masonry
- 3. Wood, Masonry or Steel

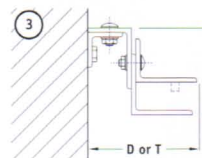
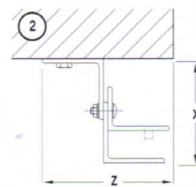
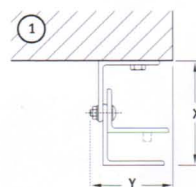

AREA CHART* Series 6000 Service Doors

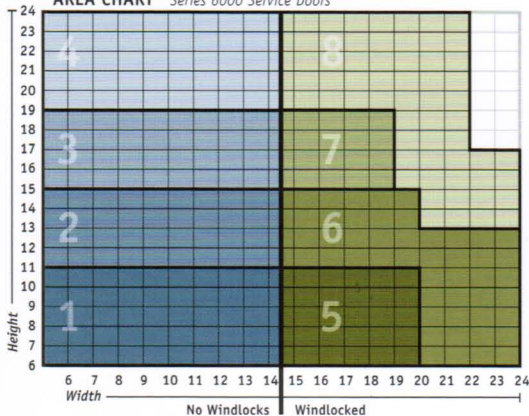

zone	H	B	T	D	X	Y	Z
1	15"	16"	6"	8-1/2"	3-7/8"	4-3/8"	6-1/2"
2	17"	18"	6"	8-1/2"	5"	4-3/8"	6-1/2"
3	21" ^{18"}	20"	6"	8-1/2"	5"	4-3/8"	6-1/2"
4	23" ^{21"}	22"	6"	8-1/2"	5"	4-3/8"	6-1/2"
5	17"	18"	6-1/2"	9-1/2"	6"	4-3/4"	7-1/2"
6	21" ^{19"}	20"	6-1/2"	9-1/2"	6"	4-3/4"	7-1/2"
7	23" ^{21"}	22"	6-1/2"	9-1/2"	6"	4-3/4"	7-1/2"
8	25" ^{23"}	24"	6-1/2"	9-1/2"	6"	4-3/4"	7-1/2"

Consult factory if headroom is critical or for sizes not listed.

*When using Area Charts, if size falls on a zone division line, go up or right to the next zone.